



BBR 500

OPTIMAL CHOICE FOR SAFE AND RELIABLE STORAGE OF BLOOD.

These models are MDD certified and designed with stable and reliable temperature uniformity from top to bottom.



MEDICAL
DEVICE
CLASS IIA



AIR FORCED
COOLING



FILTERLESS
CONSTRUCTION

SAFE BLOOD STORAGE

The BBR range comes with many special features compared to a standard pharmaceutical refrigerator. To meet the strict requirements of the MDD approval, they come with probes immersed in glycerin, extra security controller, chart recorder and secondary probes, all to preserve the integrity and traceability of the precious blood.

The BBR range comes as standard with telescopic drawer systems with lanes and dividers so that you can sort and extract the stored samples with minimum efforts – taking up less time when it really matters.

MEDICAL DEVICE

Arctiko's Blood bank refrigerator range is MDD 93/42/EEC approved and certified as class IIA

This ensures that it is approved for storing tissue or substances that are to be introduced into the human body – it is important to note the difference of class I or class II, as class I does not meet the requirement for blood storage.

To ensure maximum safety this blood bank is equipped with two controllers and a chart recorder that constantly monitors the temperature.

OPTIMIZED INTERIOR

The valuable blood is well protected and monitored in our blood banks, ensuring the high quality of your blood bags at all times. Insulated double pane glass doors will prevent condensation and ensures great temperature uniformity.

Together with the smart design, glass door and the telescopic drawers in Arctiko's BBR range you are ensured to have maximum capacity of blood bag, a great access and overview of the stored samples and still keeping the blood safe.

MAIN DIMENSION FOR BBR 500

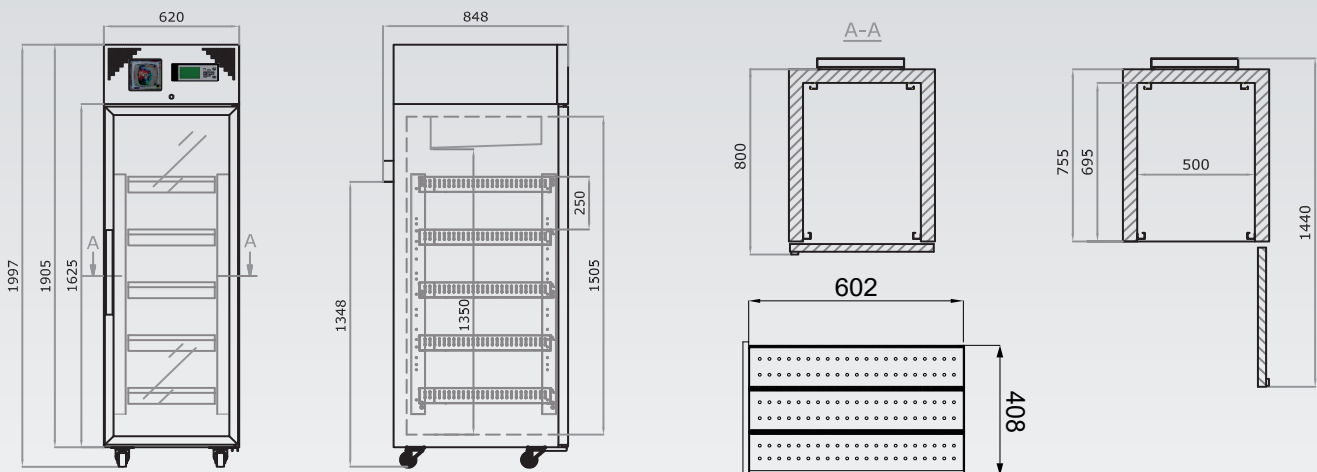

MAIN SPECIFICATIONS

Item code	DAI 1120
Temperature range (°C)	+4
Max. ambient temperature (°C)	32
Capacity (L)	523
Exterior dimensions WxDxH (mm)	620x860x1997
Interior dimensions WxDxH (mm)	500x695x1505
Weight (KG)	148
Insulation (mm)	60
Cooling technology	air forced
Controller model / probe type	G214 / PT1000

POWER

Power supply (V)	230
Frequency (Hz)	50/60
Power consumption (kWh/24H)	6,2
AMP (A)	2,4
Power (Watt)	401
Horse power (HP)	1/4

ALARM FUNCTIONS

Alarm display as text - not codes	yes
Visual / acoustic alarm	yes / yes
Power failure alarm	yes
Adjustable high / low temperature alarm	yes / yes
Open door alarm	yes
Probe failure alarm	yes
Low battery alarm	yes
Compressor failure alarm	no
Battery backup for alarms (approx. hrs.)	72

DATA LOGGING & EXTERNAL CONNECTION

Voltage free contact for remote alarm (e.g. GSM alarm module)	yes
Electronic data logger	yes
RS 485 port	yes
USB port for software update & data download	yes
Temperature chart recorder	yes

DISPLAY FEATURES

Display type	4,3" with touch buttons
Number of optional reference probes	2
Password protection for turning unit on / off	yes
Temperature graph on display	yes

OTHER FEATURES

Automatic defrost	yes
Antifreeze function	no
Vacuum release port	no
Access port for external probe etc. (int. diameter mm)	12
Light	yes
Lock with key	yes
Castors (total pcs) / castors with brake (pcs)	4 / 2
Fixed feet (pcs) / levelling feet (pcs)	no
Sub lids / inner doors (pcs)	no
Reversible door(s)	no
Adjustable drawers (pcs)	5
Max. no. of adjustable drawers (pcs)	8
Max. load per adjustable drawer (kg)	30
Max. no. of blood bags - by standard no. of adj. drawers (pcs)	240
Max. no. of blood bags - by max. no. of adj. drawers (pcs)	384

REFRIGERATION & CABINET

Number of compressors	1
Refrigerant	R290
Interior cabinet material	stainless steel
Exterior cabinet material	painted steel
Colour (exterior cabinet)	white
Foam type	polyurethane
VIP vacuum insulated panels	no

SHIPPING

Shipping weight (KG)	228
Shipping dimensions WxDxH (cm)	106x74x220
Shipping volume (m ³)	1,73

*R134a/R404a will be discontinued 2019



Telescopic drawer systems with lanes and dividers so you can sort and extract the stored samples with minimum efforts.



Arctiko's Blood bank refrigerator range is MDD 93/42/EEC approved and certified as class IIA



The BBR range comes with probes immersed in glycerin, extra security controller, chart recorder and secondary probes.

OPTIONAL ACCESSORIES

- GSM alarm module
- Modbus adapter
- Voltage stabilizer
- Voltage converters

Arctiko A/S

Oddesundvej 39 · DK-6715 Esbjerg N · Phone: +45 7020 0328
info@arctiko.com ■ arctiko.com

