



LAF 700

HIGH LEVEL OF SECURITY FOR YOUR SAMPLES, DUE TO THE GREAT COOLING PERFORMANCE WITH AIR FORCED COOLING. Automatic defrost saves you time to focus on what's most important and stores the samples safely



AIR FORCED COOLING



FILTERLESS CONSTRUCTION



FLEXIBLE SHELVES

FLEXIBLE STORAGE SOLUTIONS

This freezer is a functional freezer with flexible storage solutions. The freezer is highly customizable allowing for maximum flexibility in frozen biologicals or other samples you store within.

This allows the user to organize their unit exactly as desired. Our universal shelf and drawer guides allow you to mix shelves and drawers for flexible storage.

EXCEPTIONAL COOLING

Arctiko has combined the high quality cooling performance created by air-forced cooling and automatic defrosting.

The results meet the more stringent requirements for lower power consumption, more precise cooling uniformity, need for temperature and alarm surveillance, documentation and validation, making the LAF 700 the perfect solution for biomedical storage.

STAINLESS STEEL & AUTOMATIC DEFROST

The unit is available with stainless steel AISI 304 Exterior, so that the interior and exterior is made entirely of stainless steel, providing a stronger more resistant unit.

With Arctiko's automatic defrost system it's not required to remove samples prior to defrosting, saving you valuable time to focus on what matter the most and at the same time stores the samples safely.

MAIN DIMENSION FOR ULUF LAF 700

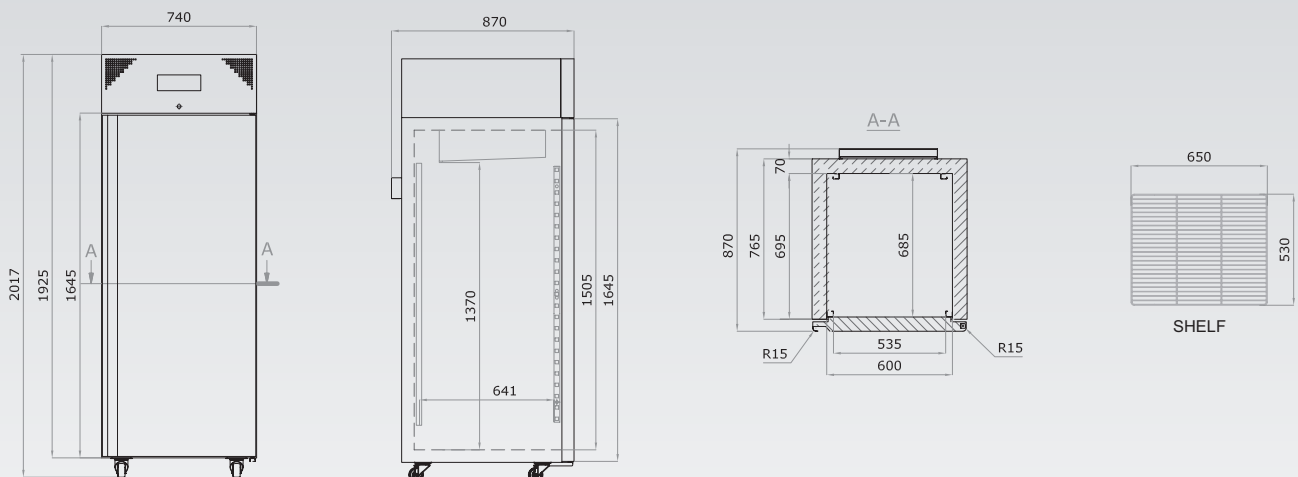

MAIN SPECIFICATIONS

Item code	DAI 0290 / DAI 0291
Temperature range (°C)	-10 / -40
Max. ambient temperature (°C)	25
Capacity (L)	618
Exterior dimensions WxDxH (mm)	740x870x2017
Interior dimensions WxDxH (mm)	600x685x1505
Weight (KG)	138
Insulation (mm)	70
Cooling technology	air forced
Controller model / probe type	G214 / PT1000

POWER

Power supply (V)	230*
Frequency (Hz)	50/60
Power consumption (kWh/24H)	14,9
AMP (A)	4,1
Power (Watt)	735
Horse power (HP)	1

ALARM FUNCTIONS

Alarm display as text - not codes	yes
Visual / acoustic alarm	yes / yes
Power failure alarm	yes
Adjustable high / low temperature alarm	yes / yes
Open door alarm	yes
Probe failure alarm	yes
Low battery alarm	yes
Compressor failure alarm	no
Battery backup for alarms (approx. hrs.)	72

DATA LOGGING & EXTERNAL CONNECTION

Voltage free contact for remote alarm (e.g. GSM module)	yes
Electronic data logger	yes
RS 485 port	yes
USB port for software update & data download	yes
Temperature chart recorder	optional

DISPLAY FEATURES

Display type	4,3" with touch buttons
Number of optional reference probes	2
Password protection for turning unit on / off	yes
Temperature graph on display	yes

OTHER FEATURES

Automatic defrost	yes
Antifreeze function	no
Vacuum release port	no
Access port for external probe etc. (int. diameter mm)	12
Light	no
Lock with key	yes
Castors (total pcs) / castors with brake (pcs)	4 / 2
Fixed feet (pcs) / levelling feet (pcs)	no
Sub lids / inner doors (pcs)	no
Reversible door(s)	yes
Fixed shelves (pcs) / adjustable shelves (pcs)	0 / 3
Max. no. of shelves (pcs) / recommended max. no. of shelves (pcs)	23 / 11
Max. load per shelf (kg)	30
Adjustable drawers (pcs)	optional
Max. no. of adjustable drawers (pcs)	8
Max. load per adjustable drawer (kg)	30

REFRIGERATION & CABINET

Number of compressors	1
Refrigerant	R290
Interior cabinet material	stainless steel
Exterior cabinet material	painted steel / stainless steel
Colour (exterior cabinet)	white / stainless steel
Foam type	polyurethane
VIP vacuum insulated panels	no

SHIPPING

Shipping weight (KG)	208
Shipping dimensions WxDxH (cm)	102x84x220
Shipping volume (m ³)	1,88

*110V/60Hz available as option

OPTIONAL ACCESSORIES

Modbus adaptor for G214 controller
Temperature chart recorder
GSM alarm module
Voltage converter
Voltage stabilizer
Racks & boxes
Perforated shelf stainless steel
Stainless steel shelf
Wire shelf

Arctiko A/S

Oddesundvej 39 · DK-6715 Esbjerg N · Phone: +45 7020 0328
info@arctiko.com ■ arctiko.com



Intertek

Intertek