

ARCTIKO Flexaline PRE 125

true cooling specialists



BIOMEDICAL REFRIGERATOR

With its low energy consumption, our eco-friendly Flexaline series offers an excellent level of flexibility, security, and reliability. Track your temperature data continuously with our digital controller which features an intergrated data logger.

▶ EXTRA SECURITY

- High/low temperature alarms and open-door alarms with audio and visual indication.
- Data logger for continuous temperature tracking.
- Backup battery for the digital controller and data logger during a possible power failure.
- Built-in lock with keys to restrict access to the stored samples.

▶ FLEXIBILITY

- The position of the shelves are easily adjustable for your storage needs.
- Easy positioning on uneven floors using four integrated leveling feet.
- Reversible glass door coming with the left-handed opening as a default.

▶ OTHER BENEFITS

- LED light can be customized for all-the-time lighting, even when the refrigerator doors are closed.
- USB port for extracting logged data.
- Remote alarm interface.
- Porthole for inserting your own temperature monitoring equipment.
- Air-forced cooling for maximum temperature uniformity, stability and quick temperature recovery following door openings.



PRE 125



The digital controller features visual and acoustic alarms, high/low-temperature alarms, open-door alarms and a data logger.



The shelves are easily adjustable to offer the best flexibility for your storage needs.



All models in our Flexaline range feature durable, cost saving LED lighting for better overview of your samples.



DATA LOGGER



USB PORT



AIR FORCED COOLING



ADJUSTABLE SHELVES



VARIOUS SAFETY FEATURES

* The pictures shown are for reference only, actual product size may vary. Please read the dimensions of the product in the specifications.

The ARCTIKO Flexaline series includes the following features, and more:

- Eco Friendly Refrigerant
- 100% HCFC & CFC FREE
- Low Energy Consumption
- Adjustable Shelves
- Key Lock on Door
- Remote Alarm Interface

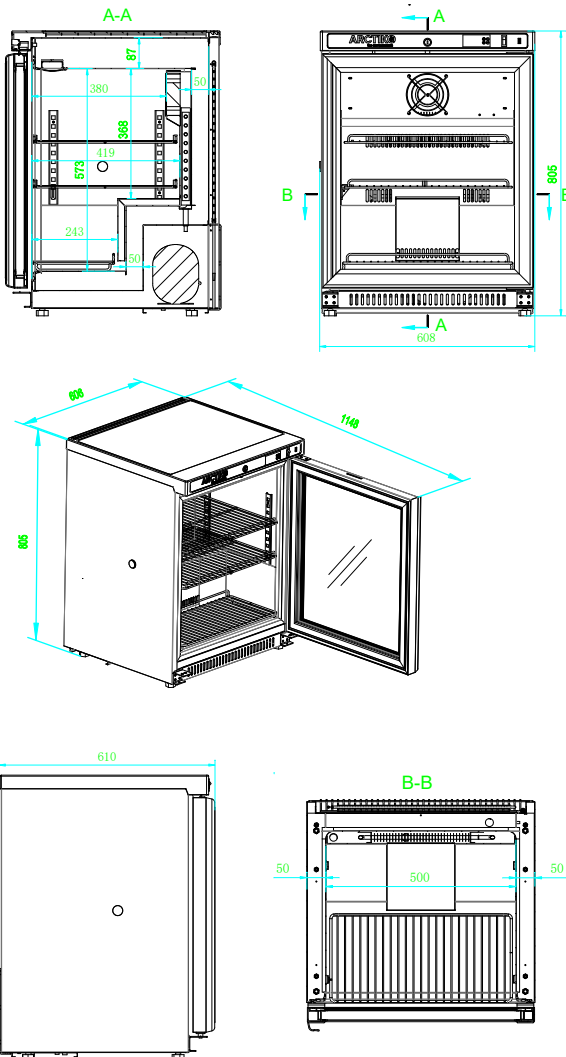

MODEL	PRE 125	
Main specifications	Item code	1900015-01
	Temperature range (°C)	2°C to 8°C
	Ambient temperature (°C)	16°C to 32°C
	Capacity (L)	[121 / 109]
	Exterior dimensions WxDxH (mm)	608×610×805
	Interior dimensions WxDxH (mm)	500×450×570
	Weight (KG)	42
	Insulation (mm)	50
	Cooling technology	Air-forced
	Controller model / probe type	Honker / NTC
Power	Power supply (V)	230
	Frequency (Hz)	50/60
	Power consumption (kWh/24h)	2,0
	AMP (A)	0,9
	Power (Watt)	135
	Horsepower (HP)	1/6
Alarm functions	Alarm (displayed as text, not codes)	No
	Visual / acoustic alarm	Yes / Yes
	Power failure alarm	Yes
	Adjustable high / low-temperature alarm	Yes / Yes
	Open door alarm	Yes
	Probe failure alarm	Yes
	Low battery alarm	Yes
Compressor failure alarm	No	
Data logging & external connection	Voltage-free contact for remote alarm (e.g. GSM alarm module)	Yes
	Electronic data logger	Yes
	USB port for software update & data download	Yes
	Temperature chart recorder	No
Display/features	Display type	Digital
	Number of optional reference probes	N/A
	Password protection for turning unit on / off	No
	Temperature graph on display	No
Other features	Automatic defrost	Yes
	Antifreeze function	Yes (2°C)
	Vacuum release port	No
	Access port for external probe etc. (int. diameter mm)	20
	Light	Yes
	Lock with key	Yes
	Castors (total pcs) / castors with brake (pcs)	No
	Fixed feet (pcs) / levelling feet (pcs)	4 / 4
	Sub lids / inner doors (pcs)	No
	Reversible door(s)	Yes
	Fixed shelves (pcs) / adjustable shelves (pcs)	0 / 3
	Max. no. of shelves (pcs) / recommended max. no. of shelves (pcs)	3 / 3
	Max load per shelf (kg)	19
	Adjustable drawers (pcs)	N/A
Max. no. of adjustable drawers (pcs)	N/A	
Max. load per adjustable drawer (kg)	N/A	
Max. no. of blood bags - by standard no. of adj. drawers (pcs)	N/A	
Max. no. of blood bags - by max. no. of adj. drawers (pcs)	N/A	
Refrigeration & cabinet	Number of compressors	1
	Refrigerant	R600a
	Interior cabinet material	Powder coated aluminum plate
	Exterior cabinet material	Powder coated galvanized steel
	Colour (exterior cabinet)	White
	Foam type	Cyclopentane
Shipping	VIP vacuum insulated panels	No
	Shipping weight (kg)	45
	Shipping dimensions WxDxH (cm)	650×664×872
	Shipping volume (m ³)	0,38